

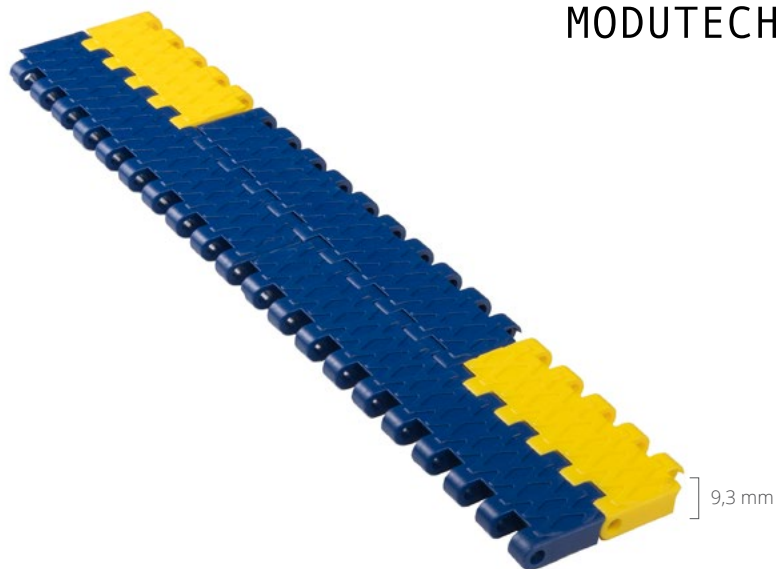

# XP254 CR

Pitch:	25,4 mm / <b>1 inch</b>
Belt Surface:	Close, Non Slip Surface
Minimum Width:	76,2 mm / <b>3 inch</b>
Open Area (%):	0%
Flight:	No
Sidewall:	No
Rod:	Ø4,5 mm / <b>0.177 inch</b> - Self Lock
Approved:	No
Curve:	No
Color:	Additional colors available
Cleanability:	Good
Belt Thickness:	9,3 mm / <b>0.366 inch</b>



## Product Features and Functional Benefits

- Chamfered belt edges.
- Reinforced bottom surface - higher product load and longer conveyors.
- Unique sprocket engagement reduces pulsation and increases load capacity.
- Close transfer applications.
- Extra power, bi-directional belt for long conveyors.
- Safety walking top surface.

## Available Moulded Module Sizes

- 152,4 mm / **6 inch** module
- 76,2 mm / **3 inch** module

## XP254 CR / Technical Information

BELT / PIN MATERIAL	BELT STRENGTH				TEMPERATURE		BELT WEIGHT
	Straight		Curve		°C / °F (min.)	°C / °F (max.)	Kg/m <sup>2</sup> / lb/ft <sup>2</sup>
	N/m	lb/ft	N/m	lb/ft			
Acetal / PA6	40250	<b>2758</b>	-	-	-43 / <b>-45.4</b>	+110 / <b>+230</b>	8,1 / <b>1.67</b>

- Belt strength and temperature values are maximum on the table.

## XP254 CR / Standard Belt Widths

BELT SERIES	WIDTH (W)				Belt With Tolerance (max.)
	PP-PE		POM		
	mm	inch	mm	inch	
XP254 CR	-	-	76,2	<b>3.0</b>	± 0,5 mm
XP254 CR	-	-	152,4	<b>6.0</b>	± 0,5 mm
XP254 CR	-	-	228,6	<b>9.0</b>	± 2 mm
XP254 CR	-	-	304,8	<b>12.0</b>	± 2 mm
XP254 CR	-	-	381,0	<b>15.0</b>	± 3 mm
XP254 CR	-	-	457,2	<b>18.0</b>	± 3 mm
XP254 CR	-	-	533,4	<b>21.0</b>	± 3 mm
XP254 CR	-	-	609,6	<b>24.0</b>	± 3 mm
XP254 CR	-	-	685,8	<b>27.0</b>	± 4 mm
XP254 CR	-	-	762,0	<b>30.0</b>	± 4 mm
XP254 CR	-	-	838,2	<b>33.0</b>	± 4 mm
XP254 CR	-	-	914,4	<b>36.0</b>	± 4 mm
XP254 CR	-	-	990,6	<b>39.0</b>	± 4 mm
XP254 CR	-	-	1066,8	<b>42.0</b>	± 4 mm
XP254 CR	-	-	1143,0	<b>45.0</b>	± 4 mm

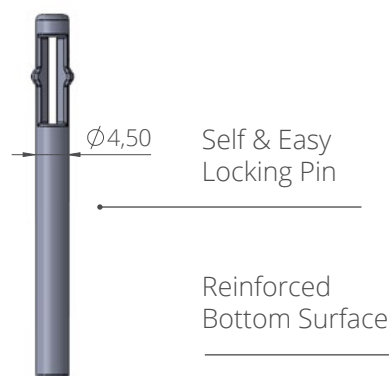
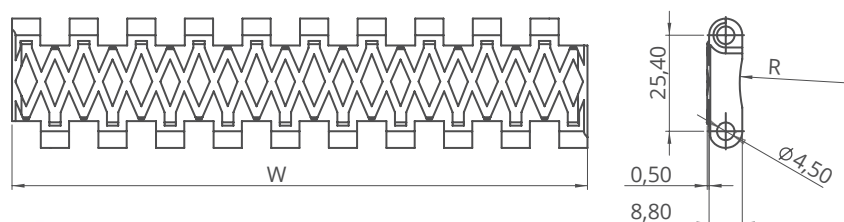

- Standard belt increments 76,2 mm.  
- Please contact with customer service for precise belt measurements.

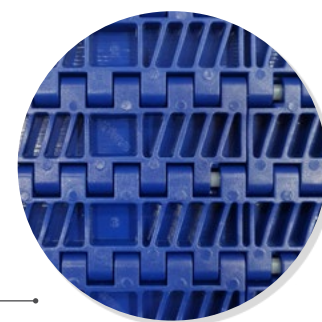



# XP254 FLT CR

Pitch:	25,4 mm / <b>1 inch</b>
Belt Surface:	Close, Smooth Surface
Minimum Width:	76,2 mm / <b>3 inch</b>
Open Area (%):	0%
Flight:	No
Sidewall:	No
Rod:	Ø4,5 mm / <b>0.177 inch</b> - Self Lock
Approved:	No
Curve:	No
Color:	Additional colors available
Cleanability:	Good
Belt Thickness:	8,8 mm / <b>0.346 inch</b>

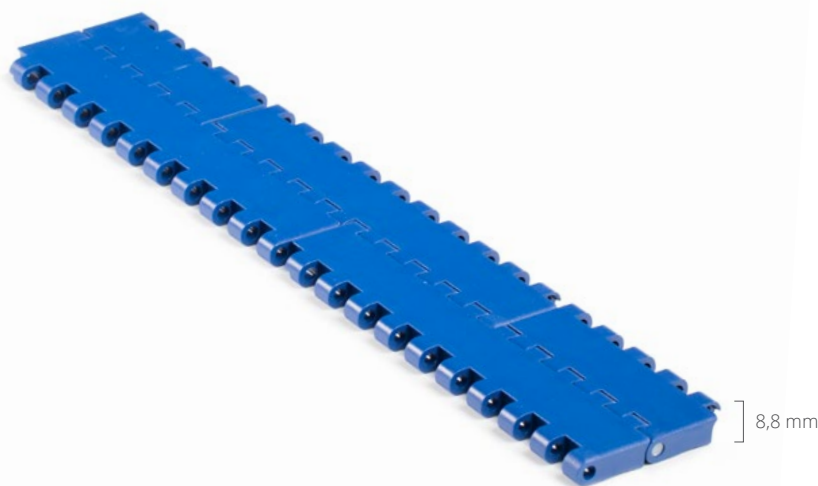

## Product Features and Functional Benefits

- Chamfered belt edges.
- Reinforced bottom surface - higher product load and longer conveyors.
- Unique sprocket engagement reduces pulsation and increases load capacity.
- Close transfer applications.
- Extra power, bi-directional belt for long conveyors.

## Available Moulded Module Sizes

- 152,4 mm / **6 inch** module
- 76,2 mm / **3 inch** module

## XP254 FLT CR / Technical Information

BELT / PIN MATERIAL	BELT STRENGTH				TEMPERATURE		BELT WEIGHT
	Straight		Curve		°C / °F (min.)	°C / °F (max.)	Kg/m <sup>2</sup> / lb/ft <sup>2</sup>
	N/m	lb/ft	N/m	lb/ft			
Acetal / PA6	40250	<b>2758</b>	-	-	-43 / <b>-45.4</b>	+110 / <b>+230</b>	8,1 / <b>1.67</b>

- Belt strength and temperature values are maximum on the table.

## XP254 FLT CR / Standard Belt Widths

BELT SERIES	WIDTH (W)				Belt With Tolerance (max.)
	PP-PE		POM		
	mm	inch	mm	inch	
XP254 FLT CR	-	-	76,2	<b>3.0</b>	± 0,5 mm
XP254 FLT CR	-	-	152,4	<b>6.0</b>	± 0,5 mm
XP254 FLT CR	-	-	228,6	<b>9.0</b>	± 2 mm
XP254 FLT CR	-	-	304,8	<b>12.0</b>	± 2 mm
XP254 FLT CR	-	-	381,0	<b>15.0</b>	± 3 mm
XP254 FLT CR	-	-	457,2	<b>18.0</b>	± 3 mm
XP254 FLT CR	-	-	533,4	<b>21.0</b>	± 3 mm
XP254 FLT CR	-	-	609,6	<b>24.0</b>	± 3 mm
XP254 FLT CR	-	-	685,8	<b>27.0</b>	± 4 mm
XP254 FLT CR	-	-	762,0	<b>30.0</b>	± 4 mm
XP254 FLT CR	-	-	838,2	<b>33.0</b>	± 4 mm
XP254 FLT CR	-	-	914,4	<b>36.0</b>	± 4 mm
XP254 FLT CR	-	-	990,6	<b>39.0</b>	± 4 mm
XP254 FLT CR	-	-	1066,8	<b>42.0</b>	± 4 mm
XP254 FLT CR	-	-	1143,0	<b>45.0</b>	± 4 mm

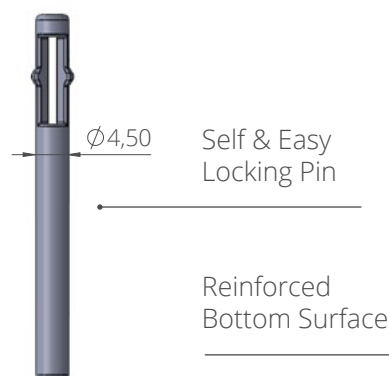
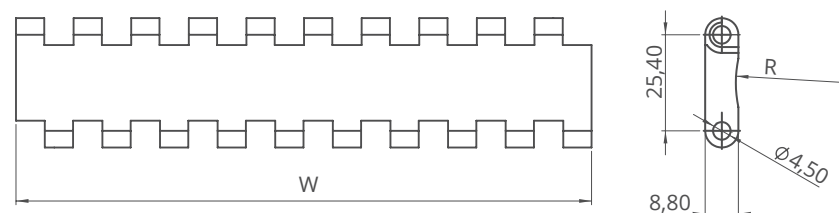

- Standard belt increments 76,2 mm.  
 - Please contact with customer service for precise belt measurements.



# XP254 C

Pitch:	25,4 mm / <b>1 inch</b>
Belt Surface:	Close, Smooth Surface
Minimum Width:	76,2 mm / <b>3 inch</b>
Open Area (%):	0%
Flight:	Yes ( T25, T50, T75, T100 )
Sidewall:	Yes ( h=25 mm, h=50 mm, h=75 mm, h=100 mm )
Rod:	Ø4,5 mm / <b>0.177 inch</b> - Self Lock
Approved:	FDA and EU
Curve:	No
Color:	Additional colors available
Cleanability:	Good
Belt Thickness:	8.8 mm / <b>0.346 inch</b>

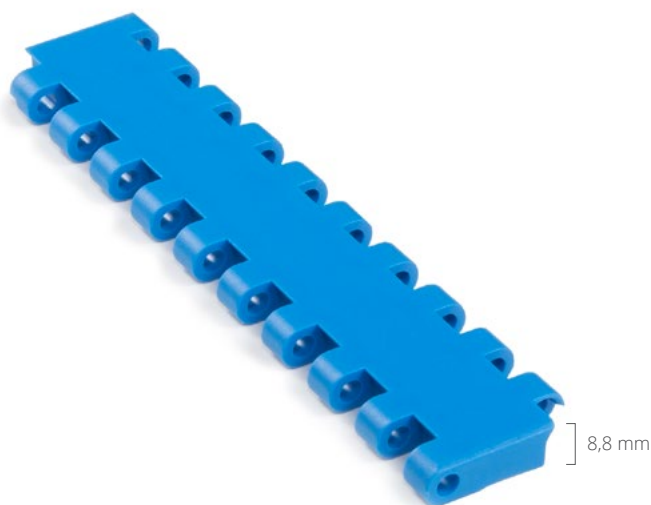

## Product Features and Functional Benefits

- Unique sprocket engagement - higher product load and longer conveyors.
- Unique sprocket engagement reduces pulsation and increases load capacity.
- Close transfer applications.
- Extra power, bi-directional belt for long conveyors.
- Chamfered belt edges.

## Available Moulded Module Sizes

- 152,4 mm / **6 inch** module
- 76,2 mm / **3 inch** module

## XP254 C / Technical Information

BELT MATERIAL	BELT STRENGTH				TEMPERATURE		BELT WEIGHT
	Straight		Curve		°C / °F (min.)	°C / °F (max.)	Kg/m <sup>2</sup> / lb/ft <sup>2</sup>
	N/m	lb/ft	N/m	lb/ft			
Polypropylene	18400	<b>1260.80</b>	-	-	+5 / <b>+41</b>	+90 / <b>+194</b>	5,50 / <b>1.13</b>
Polyethylene	9100	<b>623.55</b>	-	-	-73 / <b>-99.4</b>	+66 / <b>+150.8</b>	5,80 / <b>1.19</b>
Acetal	32100	<b>2199.55</b>	-	-	-43 / <b>-45.4</b>	+110 / <b>+230</b>	7,90 / <b>1.62</b>

- Belt strength and temperature values are maximum on the table.

## XP254 C / Standard Belt Widths

BELT SERIES	WIDTH (W)				Belt With Tolerance (max.)
	PP-PE		POM		
	mm	inch	mm	inch	
XP254 C	152,4	<b>6.0</b>	152,4	<b>6.0</b>	± 0,5 mm
XP254 C	228,6	<b>9.0</b>	228,6	<b>9.0</b>	± 2 mm
XP254 C	304,8	<b>12.0</b>	304,8	<b>12.0</b>	± 2 mm
XP254 C	381,0	<b>15.0</b>	381,0	<b>15.0</b>	± 3 mm
XP254 C	457,2	<b>18.0</b>	457,2	<b>18.0</b>	± 3 mm
XP254 C	533,4	<b>21.0</b>	533,4	<b>21.0</b>	± 3 mm
XP254 C	609,6	<b>24.0</b>	609,6	<b>24.0</b>	± 3 mm
XP254 C	685,8	<b>27.0</b>	685,8	<b>27.0</b>	± 4 mm
XP254 C	762,0	<b>30.0</b>	762,0	<b>30.0</b>	± 4 mm
XP254 C	838,2	<b>33.0</b>	838,2	<b>33.0</b>	± 4 mm
XP254 C	914,4	<b>36.0</b>	914,4	<b>36.0</b>	± 4 mm
XP254 C	990,6	<b>39.0</b>	990,6	<b>39.0</b>	± 4 mm
XP254 C	1066,8	<b>42.0</b>	1066,8	<b>42.0</b>	± 4 mm
XP254 C	1143,0	<b>45.0</b>	1143,0	<b>45.0</b>	± 4 mm

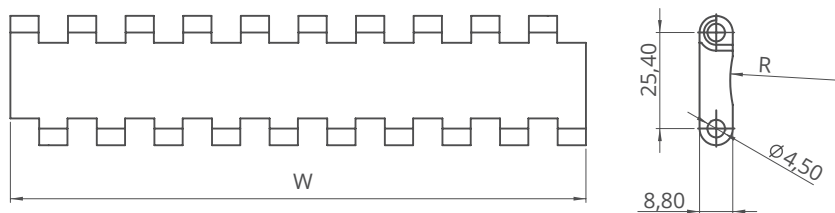

- Standard belt increments 76,2 mm.
- Non-standard belt increments 15,2 mm.
- Please contact with customer service for precise belt measurements.



# XP254 PR%22

Pitch:	25,4 mm / <b>1 inch</b>
Belt Surface:	Open, Smooth Surface
Minimum Width:	76,2 mm / <b>3 inch</b>
Open Area (%):	22%. ( Biggest opening 9,44 x 3 mm )
Flight:	Yes ( T25, T50, T75, T100 )
Sidewall:	Yes ( h=25 mm, h=50 mm, h=75 mm, h=100 mm )
Rod:	Ø4,5 mm / <b>0.177 inch</b> - Self Lock
Approved:	FDA and EU
Curve:	No
Color:	Additional colors available
Cleanability:	Good
Belt Thickness:	8,8 mm / <b>0.346 inch</b>



## Product Features and Functional Benefits

- Unique sprocket engagement - precise indexing, easy cleaning.
- Different openings to optimize performance in cooling and draining applications.
- Extra power, bi-directional belt for long conveyors.
- Unique sprocket engagement reduces pulsation and increases load capacity.
- Chamfered belt edges.

## Available Moulded Module Sizes

- 152,4 mm / **6 inch** module
- 76,2 mm / **3 inch** module

## XP254 PR%22 / Technical Information

BELT MATERIAL	BELT STRENGTH				TEMPERATURE		BELT WEIGHT Kg/m <sup>2</sup> / lb/ft <sup>2</sup>
	Straight		Curve		°C / °F (min.)	°C / °F (max.)	
	N/m	lb/ft	N/m	lb/ft			
Polypropylene	18400	<b>1260.80</b>	-	-	+5 / <b>+41</b>	+90 / <b>+194</b>	5,50 / <b>1.13</b>
Polyethylene	9100	<b>623.55</b>	-	-	-73 / <b>-99.4</b>	+66 / <b>+150.8</b>	5,80 / <b>1.19</b>
Acetal	32100	<b>2199.55</b>	-	-	-43 / <b>-45.4</b>	+110 / <b>+230</b>	7,90 / <b>1.62</b>

- Belt strength and temperature values are maximum on the table.

## XP254 PR%22 / Standard Belt Widths

BELT SERIES	WIDTH (W)				Belt With Tolerance (max.)
	PP-PE		POM		
	mm	inch	mm	inch	
XP254 PR22	152,4	<b>6.0</b>	152,4	<b>6.0</b>	± 0,5 mm
XP254 PR22	228,6	<b>9.0</b>	228,6	<b>9.0</b>	± 2 mm
XP254 PR22	304,8	<b>12.0</b>	304,8	<b>12.0</b>	± 2 mm
XP254 PR22	381,0	<b>15.0</b>	381,0	<b>15.0</b>	± 3 mm
XP254 PR22	457,2	<b>18.0</b>	457,2	<b>18.0</b>	± 3 mm
XP254 PR22	533,4	<b>21.0</b>	533,4	<b>21.0</b>	± 3 mm
XP254 PR22	609,6	<b>24.0</b>	609,6	<b>24.0</b>	± 3 mm
XP254 PR22	685,8	<b>27.0</b>	685,8	<b>27.0</b>	± 4 mm
XP254 PR22	762,0	<b>30.0</b>	762,0	<b>30.0</b>	± 4 mm
XP254 PR22	838,2	<b>33.0</b>	838,2	<b>33.0</b>	± 4 mm
XP254 PR22	914,4	<b>36.0</b>	914,4	<b>36.0</b>	± 4 mm
XP254 PR22	990,6	<b>39.0</b>	990,6	<b>39.0</b>	± 4 mm
XP254 PR22	1066,8	<b>42.0</b>	1066,8	<b>42.0</b>	± 4 mm
XP254 PR22	1143,0	<b>45.0</b>	1143,0	<b>45.0</b>	± 4 mm

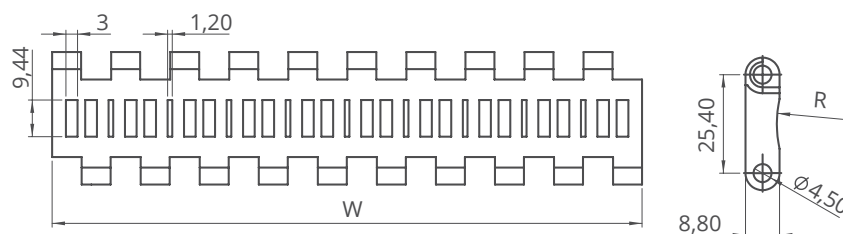

- Standard belt increments 76,2 mm.
- Non-standard belt increments 15,2 mm.
- Please contact with customer service for precise belt measurements.



# XP254 FG

Pitch:	25,4 mm / <b>1 inch</b>
Belt Surface:	Open, Smooth Surface
Minimum Width:	76,2 mm / <b>3 inch</b>
Open Area (%):	28%. ( Biggest opening 8,44 x 9,44 mm )
Flight:	Yes ( T25, T50, T75, T100 )
Sidewall:	Yes ( h=25 mm, h=50 mm, h=75 mm, h=100 mm )
Rod:	Ø4,5 mm / <b>0.177 inch</b> - Self Lock
Approved:	FDA and EU
Curve:	No
Color:	Additional colors available
Cleanability:	Good
Belt Thickness:	8,8 mm / <b>0.346 inch</b>

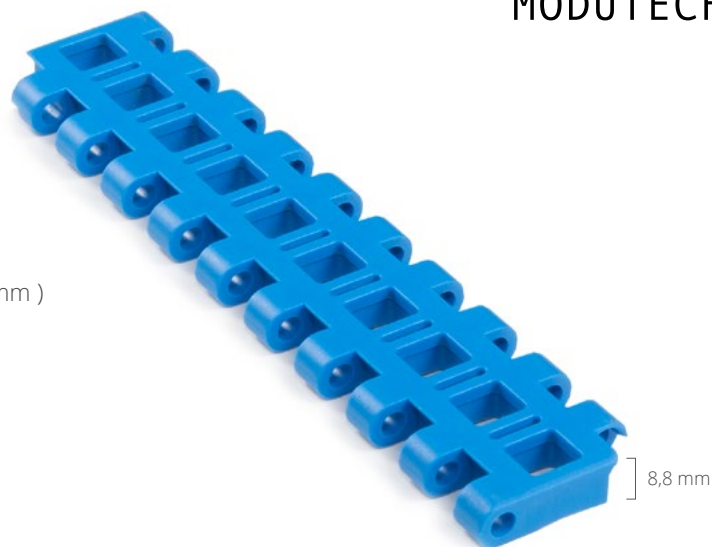

## Product Features and Functional Benefits

- Unique sprocket engagement - precise indexing, easy cleaning.
- Different openings to optimize performance in cooling and draining applications.
- Extra power, bi-directional belt for long conveyors.
- Unique sprocket engagement reduces pulsation and increases load capacity.
- Chamfered belt edges.

## Available Moulded Module Sizes

- 152,4 mm / **6 inch** module
- 76,2 mm / **3 inch** module

## XP254 FG / Technical Information

BELT MATERIAL	BELT STRENGTH				TEMPERATURE		BELT WEIGHT
	Straight		Curve		°C / °F (min.)	°C / °F (max.)	
	N/m	lb/ft	N/m	lb/ft			Kg/m <sup>2</sup> / lb/ft <sup>2</sup>
Polypropylene	18400	<b>1260.80</b>	-	-	+5 / <b>+41</b>	+90 / <b>+194</b>	5,50 / <b>1.13</b>
Polyethylene	9100	<b>623.55</b>	-	-	-73 / <b>-99.4</b>	+66 / <b>+150.8</b>	5,80 / <b>1.19</b>
Acetal	32100	<b>2199.55</b>	-	-	-43 / <b>-45.4</b>	+110 / <b>+230</b>	7,90 / <b>1.62</b>

- Belt strength and temperature values are maximum on the table.

## XP254 FG / Standard Belt Widths

BELT SERIES	WIDTH (W)				Belt With Tolerance (max.)
	PP-PE		POM		
	mm	inch	mm	inch	
XP254 FG	152,4	<b>6.0</b>	152,4	<b>6.0</b>	± 0,5 mm
XP254 FG	228,6	<b>9.0</b>	228,6	<b>9.0</b>	± 2 mm
XP254 FG	304,8	<b>12.0</b>	304,8	<b>12.0</b>	± 2 mm
XP254 FG	381,0	<b>15.0</b>	381,0	<b>15.0</b>	± 3 mm
XP254 FG	457,2	<b>18.0</b>	457,2	<b>18.0</b>	± 3 mm
XP254 FG	533,4	<b>21.0</b>	533,4	<b>21.0</b>	± 3 mm
XP254 FG	609,6	<b>24.0</b>	609,6	<b>24.0</b>	± 3 mm
XP254 FG	685,8	<b>27.0</b>	685,8	<b>27.0</b>	± 4 mm
XP254 FG	762,0	<b>30.0</b>	762,0	<b>30.0</b>	± 4 mm
XP254 FG	838,2	<b>33.0</b>	838,2	<b>33.0</b>	± 4 mm
XP254 FG	914,4	<b>36.0</b>	914,4	<b>36.0</b>	± 4 mm
XP254 FG	990,6	<b>39.0</b>	990,6	<b>39.0</b>	± 4 mm
XP254 FG	1066,8	<b>42.0</b>	1066,8	<b>42.0</b>	± 4 mm
XP254 FG	1143,0	<b>45.0</b>	1143,0	<b>45.0</b>	± 4 mm

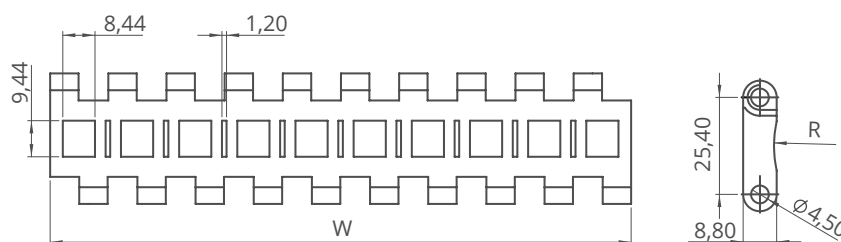

- Standard belt increments 76,2 mm.
- Non-standard belt increments 15,2 mm.
- Please contact with customer service for precise belt measurements.

# XP254 Series Sprockets and Technical Specifications



Z18



Z18

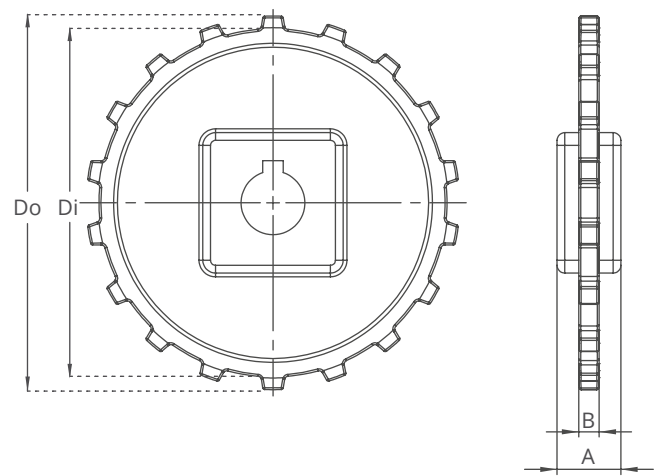
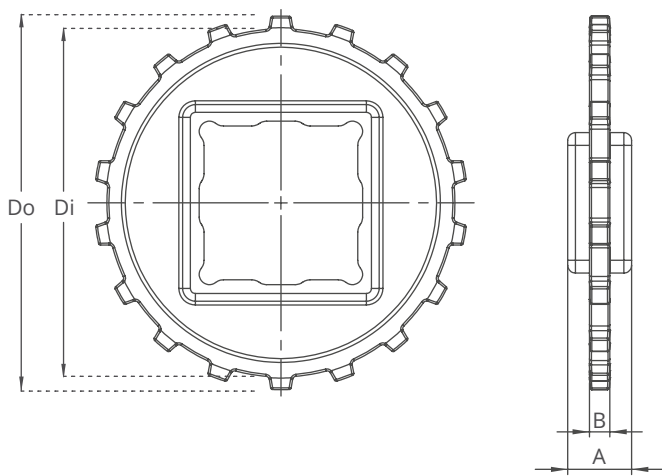

- Split moulded sprockets are available for XP254 Z15 & Z18!

## XP254 Series / Standard Sprockets Dimensions

NO. TEETH	Di mm/inch	Do mm/inch	B mm/inch	A mm/inch	Square Bore (Q) mm/inch	Round Bore (R) mm/inch	PRODUCT CODE	
							Square Type (Q)	Round Type (R)
Z8	53,2 / <b>2.09</b>	64,0 / <b>2.52</b>	8 / <b>0.31</b>	25 / <b>1</b>	25 / <b>1</b>	25-30 / <b>1-1.25</b>	XP254SQZ8*PA	XP254SRZ8*PA
Z10	71,6 / <b>2.82</b>	82,5 / <b>3.25</b>	8 / <b>0.31</b>	25 / <b>1</b>	40 / <b>1.5</b>	25-30 / <b>1-1.25</b>	XP254SQZ10*PA	XP254SRZ10*PA
Z12	89,0 / <b>3.50</b>	99,5 / <b>3.92</b>	8 / <b>0.31</b>	25 / <b>1</b>	40 / <b>1.5</b>	25-30 / <b>1-1.25</b>	XP254SQZ12*PA	XP254SRZ12*PA
Z15	114,0 / <b>4.49</b>	124,0 / <b>4.88</b>	8 / <b>0.31</b>	25 / <b>1</b>	40-60 / <b>1.5-2.5</b>	25-30 / <b>1-1.25</b>	XP254SQZ15*PA	XP254SRZ15*PA
Z18	136,4 / <b>5.37</b>	146,4 / <b>5.76</b>	8 / <b>0.31</b>	25 / <b>1</b>	40-60 / <b>1.5-2.5</b>	25-30 / <b>1-1.25</b>	XP254SQZ18*PA	XP254SRZ18*PA

\*Other sprockets and hub sizes are manufactured up to request. \*POM (Acetal) and PP (Polypropylene) sprockets raw material is available on request.

**\*Machined Split Sprockets are available for each size.**



Clamp



Machined Split Sprocket

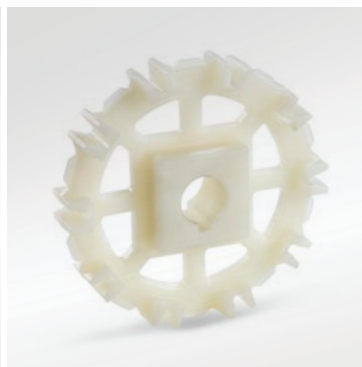

Moulded Sprocket

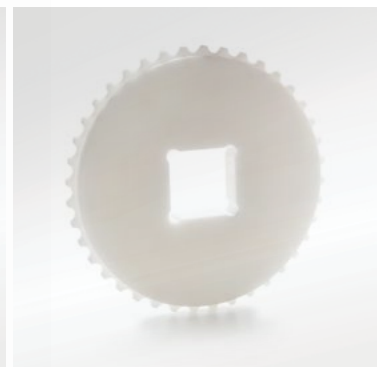

Machined Sprocket





# XP254 Series Accessories and Technical Specifications

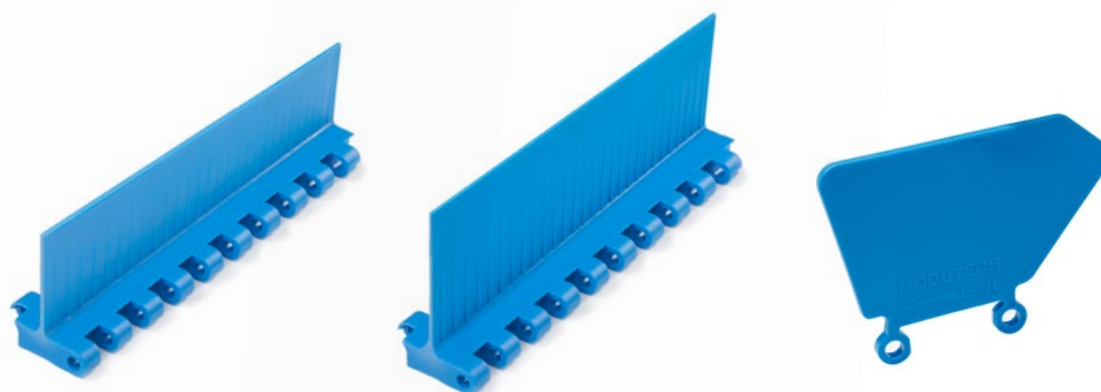

## XP254 Series / Flight & Sidewall Dimensions

XP254 Series / Flights & Sidewalls				
PRODUCT CODE	Flight Height (mm/ <i>inch</i> )	Flight Width (mm/ <i>inch</i> )	PRODUCT CODE	Sidewall Height (mm/ <i>inch</i> )
XP254T25	25 / <b>1</b>	152,4 / <b>6</b>	XP254SW25	25 / <b>1</b>
XP254T50	50 / <b>2</b>	152,4 / <b>6</b>	XP254SW50	50 / <b>2</b>
XP254T75	75 / <b>3</b>	152,4 / <b>6</b>	XP254SW75	75 / <b>3</b>
XP254T100	100 / <b>4</b>	152,4 / <b>6</b>	XP254SW100	100 / <b>4</b>

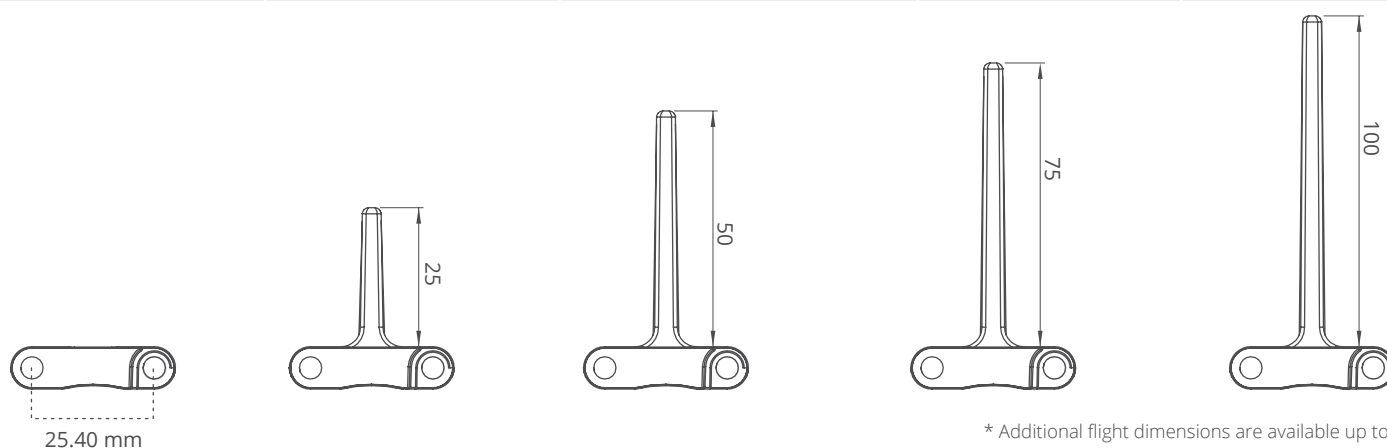

## XP254 Series / Sidewall Technical Specifications

Possible Sidewall and Flight Indents	X		Y	
	mm	<i>inch</i>	mm	<i>inch</i>
Standard, module cutting necessary	26,6	<b>1.05</b>	13,1	<b>0.52</b>
Non-standard	38,1	<b>1.50</b>	20,7	<b>0.82</b>
Standard, no module cutting	45,7	<b>1.80</b>	28,4	<b>1.12</b>
Non-standard	53,3	<b>2.10</b>	36,0	<b>1.42</b>
Standard, module cutting necessary	61,0	<b>2.40</b>	43,6	<b>1.72</b>

## XP254 Series / Flight Technical Specifications

Possible Flight Indents for XP254 Series	Z	
	mm	<i>inch</i>
Standard, module cutting	15,0	<b>0.59</b>
Standard, no module cutting	30,0	<b>1.18</b>
Standard, no module cutting	45,0	<b>1.77</b>
Standard, module cutting	60,0	<b>2.36</b>
Standard, no module cutting	76,0	<b>2.99</b>

Note: Gap between flight and sidewall minimum 2-3 mm

\*Non-standard flight indent is on request.

# XP254 Series *Engineering Information*

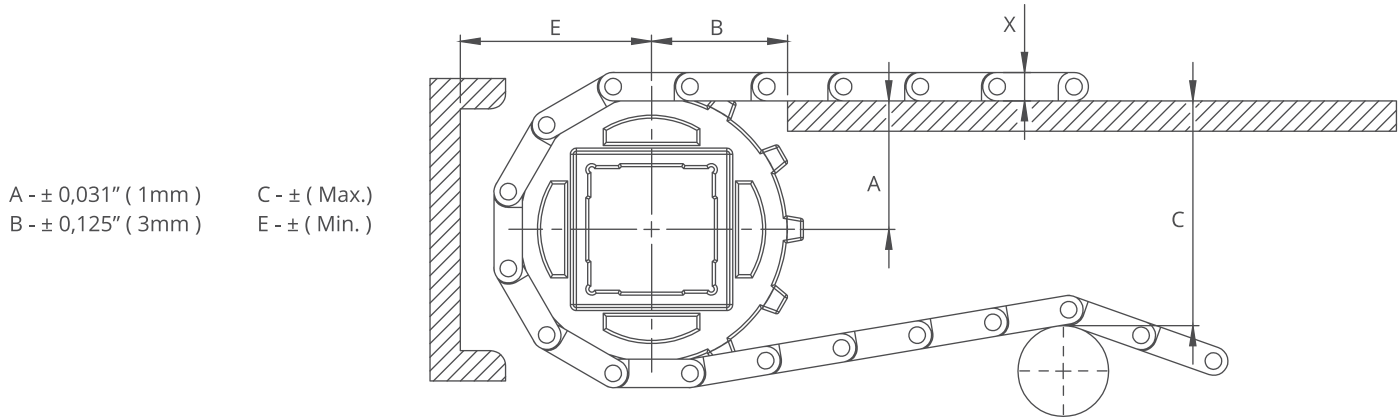

A -  $\pm 0,031''$  ( 1mm )      C -  $\pm$  ( Max. )  
 B -  $\pm 0,125''$  ( 3mm )      E -  $\pm$  ( Min. )

## XP254 Series / Conveyor Frame Dimensions

Sprockets Description			A		B		C		E		X	
Pitch Diameter		No.Teeth	Range (Bottom to Top)		inch	mm	inch	mm	inch	mm	inch	mm
inch	mm		inch	mm								
<b>XP254 FLT CR, XP254 C, XP254 FG, XP254 PR%22</b>												
<b>2.32</b>	59,0	8	<b>1.17</b>	29,8	<b>1.44</b>	36,5	<b>1.94</b>	49,3	<b>1.91</b>	48,6	<b>0.35</b>	8,8
<b>2.99</b>	76,0	10	<b>1.47</b>	37,0	<b>1.69</b>	42,9	<b>2.57</b>	65,4	<b>2.21</b>	56,2	<b>0.35</b>	8,8
<b>3.59</b>	91,2	12	<b>1.79</b>	45,5	<b>1.86</b>	47,3	<b>3.19</b>	81,1	<b>2.53</b>	64,3	<b>0.35</b>	8,8
<b>4.65</b>	118,0	15	<b>2.22</b>	56,3	<b>2.13</b>	54,1	<b>4.15</b>	105,3	<b>2.96</b>	75,1	<b>0.35</b>	8,8
<b>5.67</b>	144,0	18	<b>2.71</b>	69,0	<b>2.31</b>	58,7	<b>5.16</b>	131,0	<b>3.45</b>	87,8	<b>0.35</b>	8,8
<b>XP254 CR</b>												
<b>2.32</b>	59,0	8	<b>1.17</b>	29,8	<b>1.44</b>	36,5	<b>1.94</b>	49,3	<b>1.91</b>	48,6	<b>0.37</b>	9,3
<b>2.99</b>	76,0	10	<b>1.47</b>	37,0	<b>1.69</b>	42,9	<b>2.57</b>	65,4	<b>2.21</b>	56,2	<b>0.37</b>	9,3
<b>3.59</b>	91,2	12	<b>1.79</b>	45,5	<b>1.86</b>	47,3	<b>3.19</b>	81,1	<b>2.53</b>	64,3	<b>0.37</b>	9,3
<b>4.65</b>	118,0	15	<b>2.22</b>	56,3	<b>2.13</b>	54,1	<b>4.15</b>	105,3	<b>2.96</b>	75,1	<b>0.37</b>	9,3
<b>5.67</b>	144,0	18	<b>2.71</b>	69,0	<b>2.31</b>	58,7	<b>5.16</b>	131,0	<b>3.45</b>	87,8	<b>0.37</b>	9,3

## XP254 Series / Slider Support System For Straight Running Belts

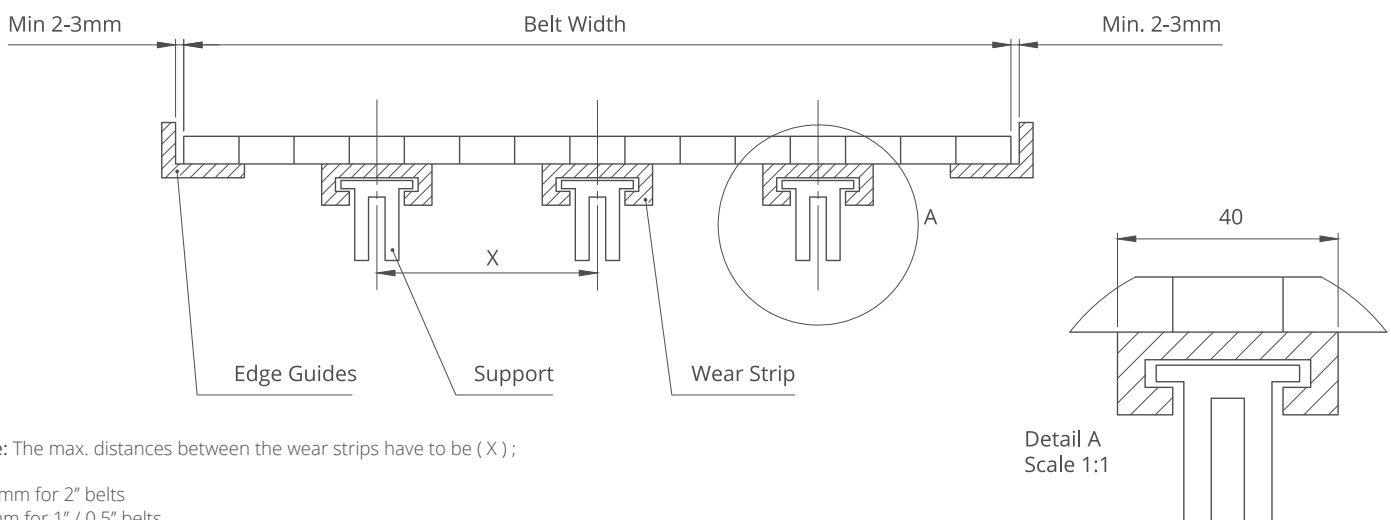

Note: The max. distances between the wear strips have to be ( X ) ;

125 mm for 2" belts  
 80 mm for 1" / 0.5" belts



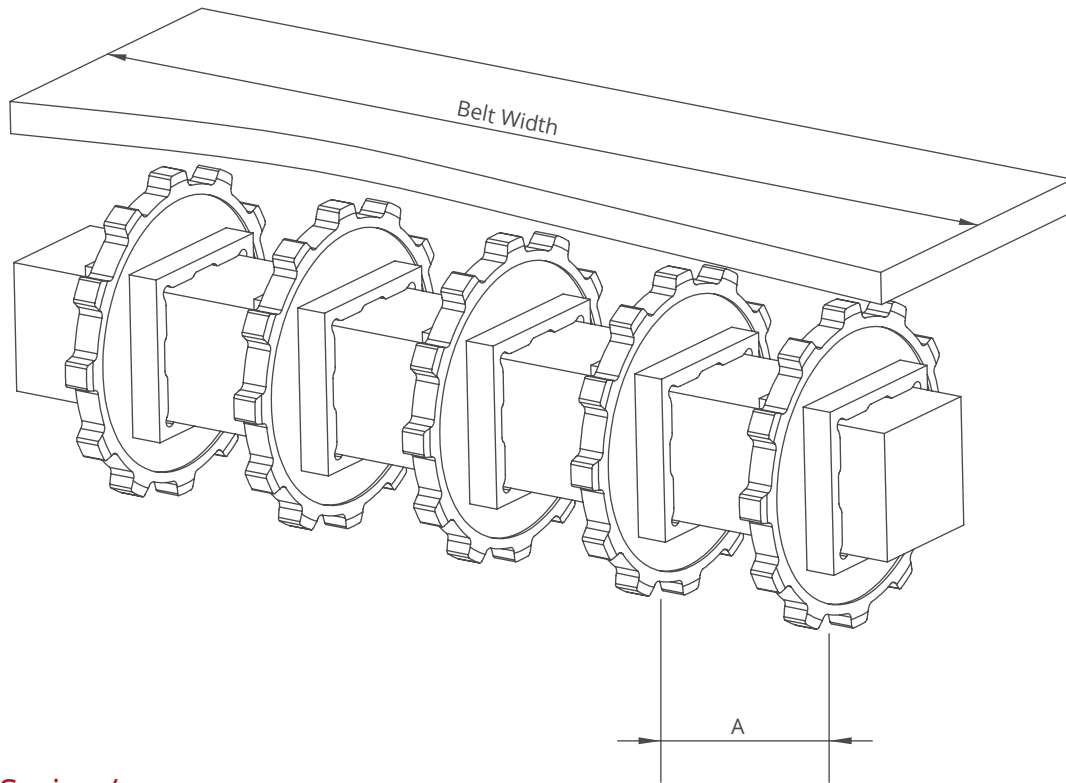

## XP254 Series / Sprockets Arrangement

Standard Belt Width		Number of sprockets per shaft		A (mm/inch)	
mm	inch	Drive Shaft	Return Shaft	Min.	Max.
152,4	6.0	2	2	60/2.36	170/6.6
228,6	9.0	2	2	60/2.36	170/6.6
304,8	12.0	3	2	60/2.36	170/6.6
381,0	15.0	4	3	60/2.36	170/6.6
457,2	18.0	5	3	60/2.36	170/6.6
533,4	21.0	5	3	60/2.36	170/6.6
609,6	24.0	6	3	60/2.36	170/6.6
685,8	27.0	6	4	60/2.36	170/6.6
762,0	30.0	7	4	60/2.36	170/6.6
838,2	33.0	7	4	60/2.36	170/6.6
914,4	36.0	8	4	60/2.36	170/6.6
990,6	39.0	8	5	60/2.36	170/6.6
1066,8	42.0	9	5	60/2.36	170/6.6
1143,0	45.0	9	5	60/2.36	170/6.6
1219,2	48.0	10	5	60/2.36	170/6.6
1295,4	51.0	10	6	60/2.36	170/6.6
1371,6	54.0	11	7	60/2.36	170/6.6
1447,8	57.0	11	7	60/2.36	170/6.6
1524,0	60.0	12	7	60/2.36	170/6.6
1600,2	63.0	12	8	60/2.36	170/6.6
1676,4	66.0	12	8	60/2.36	170/6.6
1752,6	69.0	13	8	60/2.36	170/6.6
1828,8	72.0	14	9	60/2.36	170/6.6
1905,0	75.0	14	9	60/2.36	170/6.6
1981,2	78.0	15	10	60/2.36	170/6.6
2057,4	81.0	15	10	60/2.36	170/6.6

Note: Number of sprockets depends on the belt load.